

# **RTI** INSTRUCTION AND OPERATING MANUAL

Compressor installation SKL1200  
direct driven





## Preface

This instruction and operating manual is required for compressor installations manufactured by the following company:

**RTI Transport Installaties B.V.**  
Albert Schweitzerstraat 29  
7131 PG Lichtenvoorde  
Tel. + 31 (0)544-377050

The manual provides information about the following installation:

**CVS SKL1200**                      **direct DRIVEN**

Carefully read these instructions and the compressor instruction before setting up and going into operation. These manuals contain essential information that must be read to ensure interference-free operation and to achieve longevity.

Repairs, maintenance or conversion work shall only be carried out by authorised, trained and qualified personnel that are familiar with the current safety regulations.



## Contents:

1	<b>General</b>	4
1.1	Contact details	4
1.2	Service facilities	4
1.3	Technical data compressor	4
1.4	Oil cooler	5
2	<b>Safety</b>	6
2.1	General	6
2.2	Qualification and training personnel	6
2.3	Operating safety-conscious	6
2.4	Safety instructions operator	6
2.5	Modifications and repairing spare parts	6
2.6	Modifications installation	6
3	<b>Mounting installation</b>	7
3.1	Mounting instructions RTI installation direct driven	7
4	<b>Start-up</b>	8
5	<b>Maintenance installation</b>	9
5.1	Inspection during operation	9
5.2	Weekly inspection	10
5.3	Monthly inspection	11
5.4	Half-yearly inspection	12
5.5	Maintenance checklist	13



## 1 General

### 1.1 Contact details

Please mention the PO number when contacting us by phone or mail. You will find the PO number on the type plate of the installation.

Telephone number: (0031) 544-377050  
Fax: (0031) 544-376499  
Email: info@rti.nl

### 1.2 Service facilities

For addresses of service/technical support facilities, please visit our website [www.rti.nl](http://www.rti.nl)

### 1.3 Technical data compressors

General data	Unit	
Mass moment of inertia compressor	[kgm <sup>2</sup> ]	1.52 (CR) / 1.44 (CL)
Compressor weight	[kg]	115
Permissible inclination from the horizontal during operation	[°]	all sides ±7

Tab. 1: General data

Permissible working range	Unit	
Input speed	[min <sup>-1</sup> ]	1000...1870
Suction temperature <sup>1)</sup>	[°C]	- 10...+ 40
Geodetic height <sup>1)</sup>	[m]	0...1000
Negative pressure suction side (e.g. due to soiling)	[mbar]	0...65
Maximum final overpressure at the pressure flange <sup>2)</sup>	[bar]	2.5
Running time in continuous operation <sup>3)</sup>	[h]	max. 3.0

1) For suction temperatures or heights outside the permissible working range, consult with CVS.

2) In case of increased suction temperatures or heights, the maximum permissible final pressure is reduced. Consult with CVS.

3) For continuous operation in excess of 3 hours, an oil cooler must be installed. Installation instructions on request.

Compressor performance data <sup>1)</sup>		Unit			
Input speed		[min <sup>-1</sup> ]	1000	1400	1870
Intake volume flow at a final overpressure at the pressure flange	0.0 bar		630	890	1170
	2.5 bar		510	700	1045
Coupling power at a final overpressure at the pressure flange:	0.0 bar		10,5	15,5	24
	2.5 bar		35,5	50	67
Final temperature at final overpressure = 2.0 bar		[°C]	177	177	166
max. perm. final temperature at final overpressure = 2.5bar		[°C]	250		

1) Suction pressure at suction flange = 1.0 bar, suction and ambient temperature = 20 °C, geodetic altitude max. 1000 m

Gear oil specification	Value
Specification	API CD/SF or higher
SAE viscosity class	10W40 or 15W40
Oil pressure of compressor	min. 0.5 bar (excess pressure)
Gear oil quantity compressor	4.8 litres

1) When connecting a gear oil cooler, the oil quantity must be increased commensurate with the additional volume.

#### 1.4 Oil cooler

A CVS SKL1200 is equipped with an oil-cooler.

It is very important to keep the oil-cooler clean to prevent overheating of the compressor.

**Observe the safety very carefully, the enclosure must be removed and rotating parts will be accessible.**



Oil cooler (art.no. 1342)

## **2 Safety**

### **2.1 General**

This operating manual provides important information concerning operation and maintenance of the installation that must be observed. Authorised personnel/the operator must read the manual carefully before going into operation and the manual must be kept in direct proximity of the installation.

### **2.2 Qualification and training personnel**

Any work on the compressor such as operation and maintenance shall only be carried out by authorised, skilled and qualified personnel, who are familiar with the applicable safety regulations. Repairs, maintenance and conversion work shall only be carried out by authorised personnel.

### **2.3 Operating safety conscious**

Essential safety regulations relating to the setting up, operation and maintenance of air compressors are covered by the following publications:

- Regulations for the prevention of accidents, in particular:
  - VBG 16 compressors
- Standards, in particular:
  - DIN EN 12100 Safety of machines
  - DIN EN 1012-1 Compressors and vacuum pumps, safety requirements

The latest edition of each of these regulations shall be applicable. Any special official codes and regulations, particularly safety regulations applicable to your operation in view of the local conditions shall be observed likewise. In the event of competing regulations, the most severe requirements shall apply.

### **2.4 Safety instructions operator**

Securing the compressor's operational safety is the responsibility of the operator. Damaged or non-functioning parts must be replaced immediately. If combustible materials are to be handled by the compressor, it shall be ensured that the spontaneous-ignition temperature of any dust/air mixture will not be reached. VBG 16 prescribes that a temperature limit of max. 120° C should not be exceeded (measuring point prior to contact with the conveyed product).

### **2.5 Modifications and repairing spare parts**

Unauthorized repair work and modifications are not permitted. Warranty doesn't apply to installations with a damaged seal. Original spare parts and accessories approved by the manufacturer contribute to safety. Using foreign spare parts and accessories may entail the loss of any liability for the consequences arising therefrom.

### **2.6 Modifications installation**

Without approval from RTI, it is not permitted to make any alterations to the installation.

### 3 Mounting installation

#### 3.1 Mounting instructions RTI installation powerband driven

- A** While placing the installation on a pallet, make sure the installation is approximately 30 cm off the ground (raising the installation with timber if necessary).
- B** Drive the installation up to the desired location next to the truck. Make sure the angle of the drive shaft is as small as possible. **Please find the maximum mounting angle in the mounting instructions provided by the truck manufacturer.**

The resulting angle can be 15° maximum!  
 1° to 10° is good  
 11° to 15° is excessive

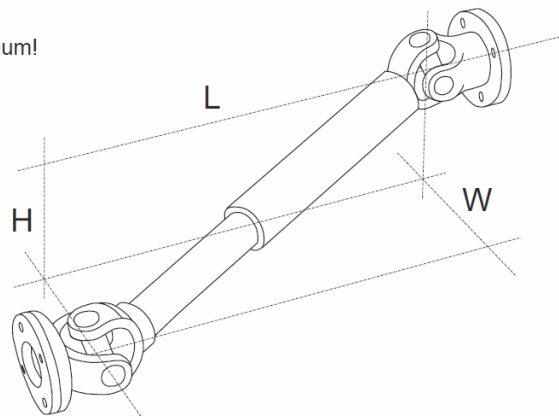

Image 3.1.1

- C** Place the installation at the same level as the chassis and parallel to the truck. Measure the PTO-shaft. Make sure the installation doesn't exceed the width of the truck.

- D** Measure the brackets and try to use all the holes in the chassis. Brackets should be painted or otherwise protected against corrosion. Use at least 2 brackets (with a box or tank combination at least 4 brackets should be used)

- E** Mount the brackets onto the chassis and onto the installation.

- F** The installation is equipped with a 24 Volt fan: connect the wires of the switch box (image 3.1.2).

- G** Cover the brackets with an aluminium panel.

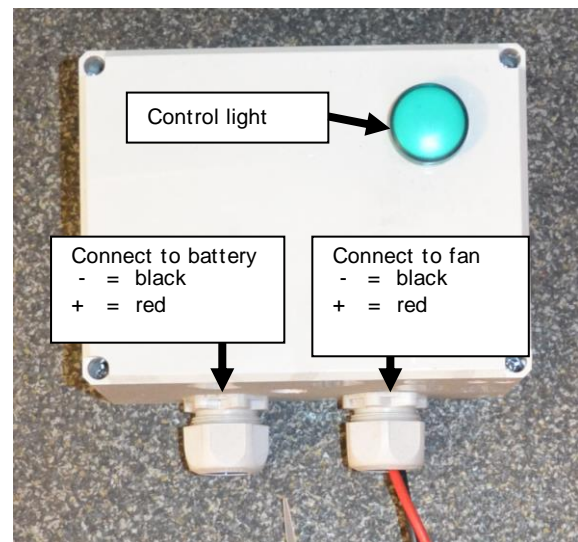

image 3.1.2

#### NOTE

With a vacuum installation the vacuum valve must be set to -0.5 bar. Please note: the vacuum valve should be set when testing the installation before initial operation. The vacuum valve has not been set when the installation is delivered as a building kit (without mounting by RTI).



## 4 Start-up

Observe the following prior to start-up:

**IT IS OF VITAL IMPORTANCE THAT THERE ARE NO PERSONS UNDERNEATH THE VEHICLE DURING START-UP AND DURING OPERATION!!**

### ● Preservation

The rotors of the compressor are sprayed with an anti-corrosion agent prior to delivery. During the initial operation this agent will evaporate as the compressor heats up. Since the RTI-installations are all tested a few minutes, the anti-corrosion agent on the rotors will have evaporated.

### ● Topping up of lubricating oil

Check before start-up if the correct amount of lubricating oil is on the dipstick. The correct level corresponds to the mark on the dip stick. See chapter 1.4

### ● Checking the direction of rotation

Looking towards the drive shaft, the compressor must rotate clockwise.

The compressor must be started and stopped in a fully unloaded condition, without any back pressure.

Never start against any back pressure. (Remove blanking cap or connect hoses.) This could damage the shear pin coupling.

### ● Switching-on

We refer to the truck's instruction booklet, to switch on the PTO (only with closed enclosure). It is very important not to exceed the maximum speed range as reported in the inspection report and as displayed on the dashboard of the driver's cab.

Together with the compressor, the integral oil pump will also start to run and will ensure the supply of oil to lubricate the bearings and the gears. The oil pressure shall not fall below 0,3 bar. With cold oil, it may occur that the required oil pressure is built up only after a short operating time, due to higher viscosity. Check the air indicator clock. When "red", the compressor must be switched off. See inspection checklist.

The minimum engine speed cannot go below 800 rpm without the truck dealer's consent.

### ● Vacuum installation

With a vacuum installation the vacuum valve must be set to -0.5 bar. Please note: the vacuum valve should be set when testing the installation before initial operation. The vacuum valve has not been set when the installation is delivered as a building kit (without mounting by RTI).

## CAUTION

After a short period of time, the compressor will reach maximum running temperature.

When switched-on, it not permitted to loosen the catches on the enclosure!!

We recommend the use of safety gloves when disconnecting hoses or couplings from the enclosure, after the installation has been switched-on.

## NOTE

When cleaning the tank vehicle by means of a steam jet device, water may penetrate inside the compressor via the oil seals. To avoid corrosion, the compressor shall be set into operation for a short period of time after cleaning.

The non-return valve installed in the discharge silencer is not intended to prevent flow-back of material. Its purpose is to prevent the reverse operation of the compressor for an extended period of time.

**It is not permitted to use the attached relief valve as blow-off control valve.**





## 5 Maintenance installation

### 5.1 INSPECTION DURING OPERATION

- A: Check the oil manometer before every start-up. The oil pressure must not drop below the minimum value of 0.3 bar, (normally 1-3 bar). When outside temperature is low it may take a few seconds before the oil pressure is visible.
- B: Check the air filter indicator.  
If the red mark is visible, the air intake filter is soiled and poses a risk of overheating and damages.
- C: The safety valve must open at maximum air pressure.  
This valve must NOT be used as blow-off valve. To prevent overheating in the enclosure the valve at the silo tank must blow off before the compressor valve does. (blow-off pressure 2.5 bar)
- D: Pay attention to any unusual sounds or peculiarities near the installation.
- E: The fan must rotate to a switched-on PTO  
Check the functioning of the fan.

**This check may only be carried out by skilled mechanics. Observe the safety very carefully, the enclosure must be removed and rotating parts will be accessible.**

## 5.2 WEEKLY INSPECTION

\*\*\*\*\*  
**ONLY CARRY OUT WHEN INSTALLATION IS COOL AND AT A STANDSTILL**  
 \*\*\*\*\*

**A:** Check the level of lubricating oil weekly.

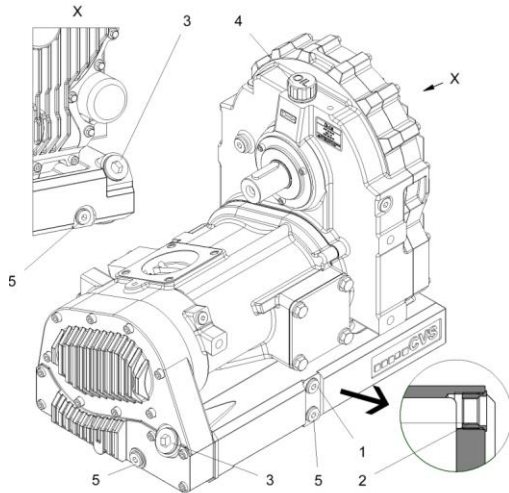

Unscrew the upper screw plug (1) from the oil pan and check whether the oil reaches the lower edge of the threaded hole (2) (see magnification).

- Correct oil level if necessary. If the oil level is too high: The oil flows out of the control bore. Collect oil and dispose of in accordance with legal regulations.
- If the oil level is too low: Top up with oil. To do this, either unscrew the higher of the two filling screws (3) or the vent plug (4) and slowly fill in the oil until the oil reaches the lower edge of the threaded hole (2).

**ATTENTION!**

When filling via the bore of the vent plug (4), the oil level changes only after a time delay due to the oil flowing in.

**B:** Check the air intake filter at regular intervals.



Clean or replace the air filter if necessary.

\* Please note that the air filter is reinserted in the same position (paying attention to the front and back of the element).

Also check the functioning of the air indicator.

→Air filter

**C:** It is important to check the airflow and cleanliness of the fan louvres to prevent overheating of the compressor.  
 (compressed air cooler and when installed the oil cooler)

**This check may only be carried out by skilled mechanics. Observe the safety very carefully, the enclosure must be removed and rotating parts will be accessible.**

**D:** Check the functioning of the fan. Check if the control light is on (image 3.1.2). You will find the safety fuse in the switch box.



### 5.3 MONTHLY INSPECTION

\*\*\*\*\*  
**ONLY CARRY OUT WHEN INSTALLATION IS COOL AND AT A STANDSTILL**  
\*\*\*\*\*

**This check may only be carried out by skilled mechanics. Observe the safety very carefully, the enclosure must be removed and rotating parts will be accessible.**

- A:** Lubricate cross journals of the PTO-shaft (after approx. 40 operating hours)
- B:** Lubricate latches and padlock and check their functioning.
- C:** Preserve the compressor when it has been at a standstill for a longer period of time. (lubricate the compressor's rotor with oil to prevent corrosion)

To carry out the following inspections it is necessary to start the installation without enclosure. Please note the dangers that can occur as a result of access to:

- hot parts as compressor and silencer (150 ° C)
- rotating parts such as the transmission and the fan
- high sound levels (> 85 dB)

**HEARING PROTECTION OBLIGATED!!**

**DURING INSPECTION NO ONE IS ALLOWED UNDERNEATH THE VEHICLE!!**

- D:** Check the functioning of the safety valve.  
Air pressure measured at the discharge flange of the compressor may not exceed a maximum gauge pressure of 2.5.  
Potential pressure loss between compressor and silo tank of 0.2 up to 0.3 bar
- E:** Check flanges/packing, rubber compensators etc. in the enclosure for air leakages to avoid loosening of the insulation material and overheating.
- F:** Check the functioning of the fan.

## 5.4 HALFYEARLY INSPECTION

\*\*\*\*\*  
**ONLY CARRY OUT WHEN INSTALLATION IS COOL AND AT A STANDSTILL**  
 \*\*\*\*\*

**This check may only be carried out by skilled mechanics. Observe the safety very carefully, the enclosure must be removed and rotating parts will be accessible.**

**A:** Change the lubricating oil simultaneously with the truck's engine oil, at least twice a year.

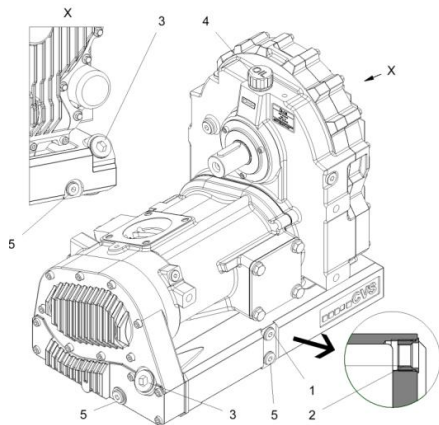

- Open the oil drain screw (5) at the lowest point, drain oil.
- Dismantle oil filter with the aid of a strap wrench. Lightly oil the new oil filter on the rubber seal and tighten by hand.
- Close oil drain screws, fill in oil as described in and check filling level.

(oil type 15W40 or 10W40 synthetic oil)

**B:** Change the oil filter.  
 Please find the instructions to demount the oil filter in the manual provided with the installation.

**C:** Demount the non-return valve installed in the discharge silencer and check for proper functioning.

**D:** Check the functioning of the fan.

**E:** Check if the control light is on. You will find the safety fuse in the switch box.

**F:** Check the shear pin coupling for leeway space.

### **NOTE:**

**The operating instructions provided by the compressor manufacturer should be read carefully.**

## 5.5 Maintenance/inspection list

Along with every maintenance inspection the maintenance checklist on the next page must be filled out. We recommend sending the checklist to RTI after filling it out.

Mail: [info@rti.nl](mailto:info@rti.nl)  
 Fax: (0031) 544-376499

Hold on to the checklist, the checklist can be handed to the mechanic when the next maintenance service is due or when the installation needs to be repaired. (Do not forget to take the checklist back with you)

# Maintenance checklist



<b>Firma</b>	:	<b>Date maintenance</b>	:
<b>Name mechanic</b>	:	<b>Compressor</b>	:
<b>Address</b>	:	<b>Serial number</b>	:
	:	<b>Installation-no.</b>	: PO.....
<b>Truck</b>	:	<b>Year manufactured</b>	:
<b>Truck nr.</b>	:		:
<b>Licence plate no.</b>	:	<b>Chassis:</b>	<b>No. KM driven:</b>

**Actions**

**COMPRESSOR:**

- Drain oil
- Change oil filter
- Check potential leakage machine
- Change + top up oil
- Check oil hose for potential cracks/damages

**CLEAN COMPRESSOR:**

- Check rotors for damages or greasiness
- Flush compressor twice with 1/4L degreaser
- Check rubber compensator for cracks replace if necessary
- Check aluminium pipes and silencers for cracks and leakage
- Check the indicator's piping for cracks and leakage

**AIRFILTER:**

- Take air filter lid off
- Check the lid's latches
- Check if the insulation material is secured in suction part if this isn't the case repair and finish with sealant
- Check functioning of air filter indicator
- Clear intake-side of degreaser residue
- Place a new air filter element

**ENCLOSURE:**

- Check the insulation material in the enclosure for damages (cover, back panel, floor panel) if necessary repair and finish with sealant
- Check if the fan louvers are open
- Check if the discharge silencer is clean (flow)
- Check the frame and brackets for potential cracks
- Check if the bolts of the brackets are secured
- Check the seal washers of the Storz coupling for cracks and leakage
- Check the functioning of the cover's latches
- Tighten the bolts of the mounting brackets

**TRANSMISSION:**

- Check the PTO-shaft for leeway in the cross journals
- Lubricate the PTO-shaft with EP grease (red)
- Tighten the bolts of the PTO-shaft flanges

**TESTING:**

- Operation test run of machine
- Check density of discharge sides
- Check pressure valve for 2.5 bar
- Check functioning of indicators
- Check the engine for unusual sounds
- Clean the window pane