

RTI INSTRUCTION AND OPERATING MANUAL

Compressor installation B600





Preface

This instruction and operating manual is required for compressor installations manufactured by the following company:

RTI Transport Installaties B.V.
Albert Schweitzerstraat 29
7131 PG Lichtenvoorde
Tel. + 31 (0)544-377050

The manual provides information about the following installation:

Blackmer B600

Carefully read these instructions and the compressor instruction before setting up and going into operation. These manuals contain essential information that must be read to ensure interference-free operation and to achieve longevity.

Repairs, maintenance or conversion work shall only be carried out by authorised, trained and qualified personnel that are familiar with the current safety regulations.



Contents:

1	General	4
1.1	Contact details	4
1.2	Service facilities	4
1.3	Technical data compressor	4
1.4	Oil	5
1.5	Oil cooler	5
2	Safety	6
2.1	General	6
2.2	Qualification and training personnel	6
2.3	Operating safety-conscious	6
2.4	Safety instructions operator	6
2.5	Modifications and repairing spare parts	6
2.6	Modifications installation	6
4	Start-up	7
5	Maintenance installation	8
5.1	Inspections	8
5.2	Maintenance checklist	8

1 General

1.1 Contact details

Please mention the PO number when contacting us by phone or mail. You will find the PO number on the type plate of the installation.

Telephone number: (0031) 544-377050

Fax: (0031) 544-376499

Email: info@rti.nl

1.2 Service facilities

For addresses of service/technical support facilities, please visit our website www.rti.nl

1.3 Technical data compressor

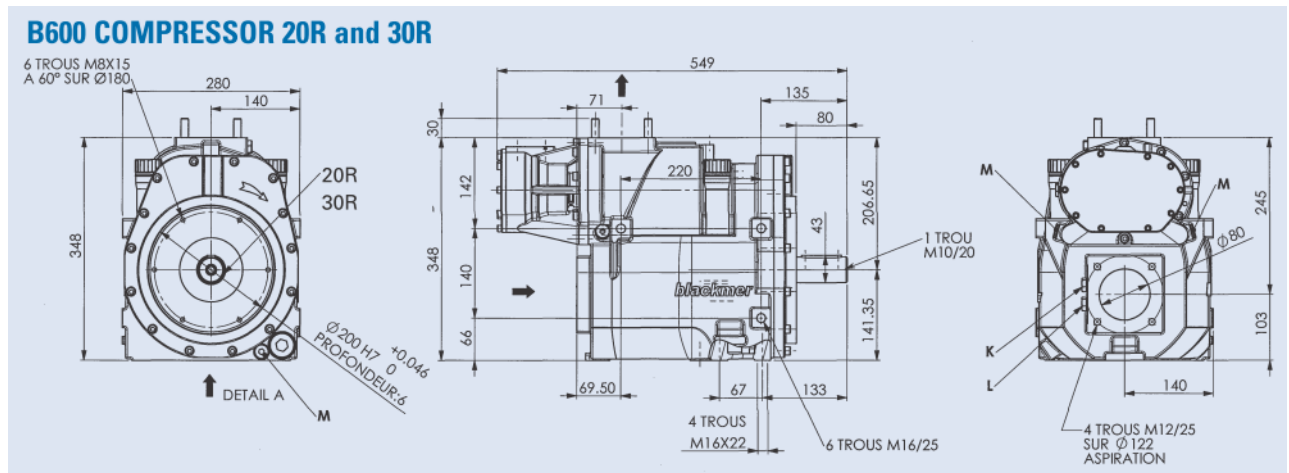

Speed (rpm)

COMPRESSOR SPEED

VERSION	1	2	3	4	5
13R	780	910	1040	1170	1300
15L	900	1050	1200	1350	1500
19R	1170	1365	1560	1755	1950
20R	1200	1400	1600	1800	2000

Flow (m³/hr) / Power (kW)

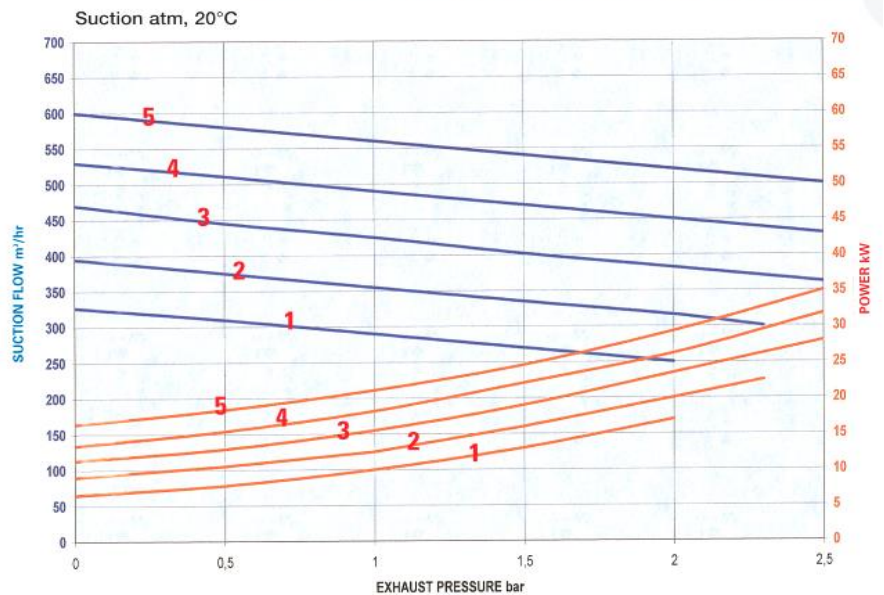

1.4 Oil

Oil grade	Below -10° C	SAE 10W40
	Between -10° C and 30° C	SAE 15W40
	Above 30° C	SAE 15W50
Oil quantity	4,2 L	

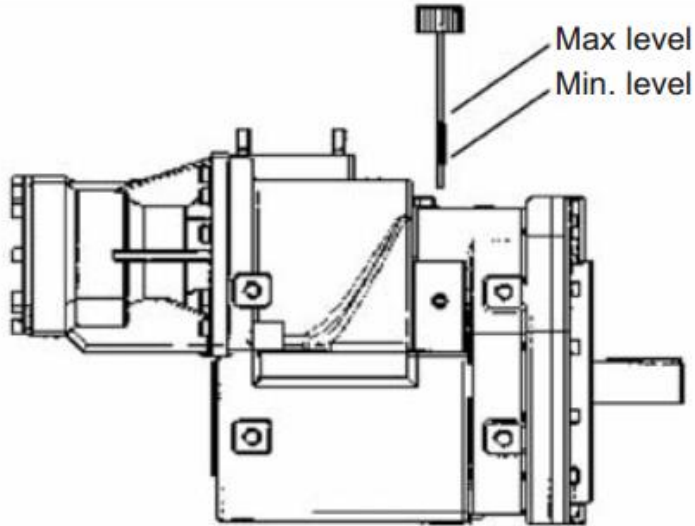

The oil level must under no circumstances exceed the maximum marker on the oil gauge. (The level is taken after the gauge has been completely screwed onto the filling tube.)

1.5 Oil Cooler

When operating continuously over 3 hours, an oil cooler must be installed. When installing the oil cooler the oil volume should be increased by a volume equal to the extra flow rate.



Image 1.5.1 Oil cooler (art.no. 1342)



2 Safety

2.1 General

This operating manual provides important information concerning operation and maintenance of the installation that must be observed. Authorised personnel/the operator must read the manual carefully before going into operation and the manual must be kept in direct proximity of the installation.

2.2 Qualification and training personnel

Any work on the compressor such as operation and maintenance shall only be carried out by authorised, skilled and qualified personnel, who are familiar with the applicable safety regulations. Repairs, maintenance and conversion work shall only be carried out by authorised personnel.

2.3 Operating safety conscious

Essential safety regulations relating to the setting up, operation and maintenance of air compressors are covered by the following publications:

- Regulations for the prevention of accidents, in particular:
 - VBG 16 compressors
- Standards, in particular:
 - DIN EN 12100 Safety of machines
 - DIN EN 1012-1 Compressors and vacuum pumps, safety requirements

The latest edition of each of these regulations shall be applicable. Any special official codes and regulations, particularly safety regulations applicable to your operation in view of the local conditions shall be observed likewise. In the event of competing regulations, the most severe requirements shall apply.

2.4 Safety instructions operator

Securing the compressor's operational safety is the responsibility of the operator. Damaged or non-functioning parts must be replaced immediately. If combustible materials are to be handled by the compressor, it shall be ensured that the spontaneous-ignition temperature of any dust/air mixture will not be reached. VBG 16 prescribes that a temperature limit of max. 120° C should not be exceeded (measuring point prior to contact with the conveyed product).

2.5 Modifications and repairing spare parts

Unauthorized repair work and modifications are not permitted. Warranty doesn't apply to installations with a damaged seal. Original spare parts and accessories approved by the manufacturer contribute to safety. Using foreign spare parts and accessories may entail the loss of any liability for the consequences arising therefrom.

2.6 Modifications installation

Without approval from RTI, it is not permitted to make any alterations to the installation.



3 Start-up

Observe the following prior to start-up:

IT IS OF VITAL IMPORTANCE THAT THERE ARE NO PERSONS UNDERNEATH THE VEHICLE DURING START-UP AND DURING OPERATION!!

● **Preservation:**

The rotors of the compressor are sprayed with an anti-corrosion agent prior to delivery. During the initial operation this agent will evaporate as the compressor heats up. Since the RTI-installations are all tested a few minutes, the anti-corrosion agent on the rotors will have evaporated.

● **Topping up of lubricating oil:**

Check before start-up if the correct amount of lubricating oil is on the dipstick. The correct level corresponds to the mark on the dip stick. See chapter 1.4

● **Checking the direction of rotation:**

Looking towards the drive shaft, the compressor must rotate clockwise.

The compressor must be started and stopped in a fully unloaded condition, without any back pressure.

Never start against any back pressure. (Remove blanking cap or connect hoses.)

● **Switching-on:**

We refer to the truck's instruction booklet, to switch on the PTO (only with closed enclosure).

It is very important not to exceed the maximum speed range as reported in the inspection report and as displayed on the dashboard of the driver's cab.

Together with the compressor, the integral oil pump will also start to run and will ensure the supply of oil to lubricate the bearings and the gears. The oil pressure shall not fall below 0,3 bar. With cold oil, it may occur that the required oil pressure is built up only after a short operating time, due to higher viscosity. Check the air indicator clock. When "red", the compressor must be switched off. See inspection checklist.

CAUTION:

After a short period of time, the compressor will reach maximum running temperature.

When switched-on, it not permitted to loosen the catches on the enclosure!!

We recommend the use of safety gloves when disconnecting hoses or couplings from the enclosure, after the installation has been switched-on.

NOTE:

When cleaning the tank vehicle by means of a steam jet device, water may penetrate inside the compressor via the oil seals. To avoid corrosion, the compressor shall be set into operation for a short period of time after cleaning.

The non-return valve installed in the discharge silencer is not intended to prevent flow-back of material. Its purpose is to prevent the reverse operation of the compressor for an extended period of time.

It is not permitted to use the attached relief valve as blow-off control valve.



4 Maintenance installation

4.1 Inspections

ONLY CARRY OUT WHEN INSTALLATION IS COOL AND AT A STANDSTILL

Change the compressor oil and clean the magnetic plugs after the first 10 hours or first week operating.

◆ Weakly

The compressor should be run for at least 15 minutes to prevent moisture from collecting inside. This will reduce the risk of corrosion damage. It is also important to clean the outer surfaces of the compressor, the compressor cooling wings and the multiplier inlet grille.

◆ Monthly

Drive shaft Oil	Lubricate cross journals after 40 operating hours Check the oil level (do not overfill) and check the breather inside the oil gauge for cleanliness, clean with an air blower if necessary
Checks	Check for potential oil and air leakage

◆ Half yearly

Air filter Piping	Clean/change air filter Check functioning/fastening of the piping and check for potential cracks Check hose clamps/compensators and replace if necessary
----------------------	--

◆ Yearly

Air filter Oil	Change air filter yearly or every 500 operating hours Change oil yearly or every 500 operating hours, oil type 15W40 motor oil synthetic
-------------------	---

NOTE:

The operating instructions provided by the compressor manufacturer should be read carefully.

4.2 Maintenance checklist

Along with every maintenance inspection the maintenance checklist on the next page must be filled out. We recommend sending the checklist to RTI after filling it out.

Mail: info@rti.nl
 Fax: (0031) 544-376499

Hold on to the checklist, the checklist can be handed to the mechanic when the next maintenance service is due or when the installation needs to be repaired. (Do not forget to take the checklist back with you)

Maintenance checklist



Firma	:	Date maintenance	:
Name mechanic	:	Compressor	:
Address	:	Serial number	:
	:	Installation-no.	: PO.....
Truck	:	Year manufactured	:
Truck nr.	:		:
Licence plate no.	:	Chassis:	No. KM driven:

Actions

COMPRESSOR:

- Drain oil
- Clean oil filter
- Clean magnetic plugs
- Check potential leakage machine
- Change + top up oil
- Check oil hose for potential cracks/damages

SILENCER:

- Demount discharge silencer
- Check rotors for damages or greasiness
- Flush compressor twice with 1/4L degreaser
- Check rubber compensator for cracks replace if necessary
- Check aluminium/stainless steel pipes and silencers for cracks and leakage
- Mount discharge silencer
- Check the indicator's piping for cracks and leakage

AIRFILTER:

- Take air filter lid off
- Check the lid's latches
- Check functioning of air filter indicator
- Clear intake-side of degreaser residue
- Place a new air filter element

FRAME:

- Check the frame and brackets for potential cracks
- Check if the bolts of the brackets are secured
- Check the seal washers of the Storz coupling for cracks and leakage
- Tighten the bolts of the mounting brackets

TRANSMISSION:

- Check the PTO-shaft for leeway in the cross journals
- Lubricate the PTO-shaft with EP grease (red)
- Tighten the bolts of the PTO-shaft flanges

TESTING:

- Operation test run of machine
- Check density of discharge sides
- Check pressure valve for 2.5 bar
- Check functioning of indicators
- Check the engine for unusual sounds